

EASY A

1.

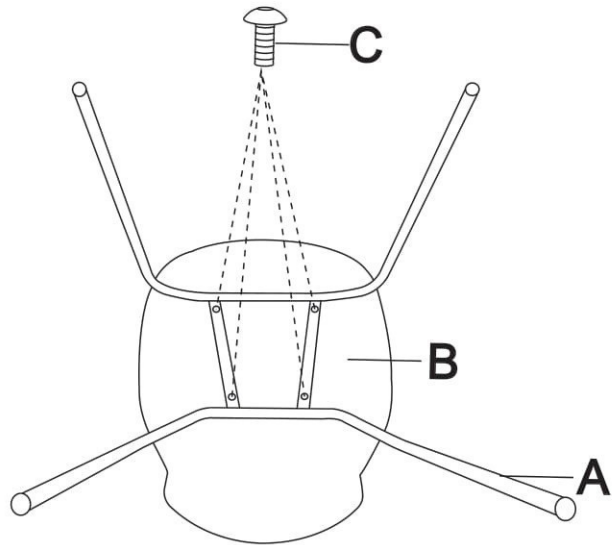

3.

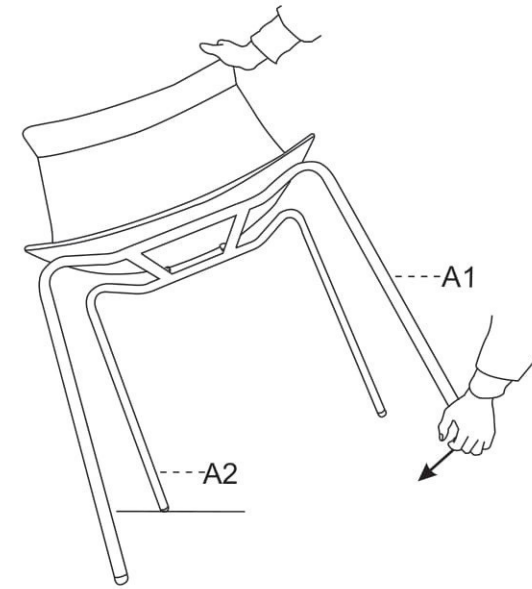

UWAGA:

Je li po monta u noga A1 nie znajduje si w pobli u podstawy jak w kroku 2, nale y podnie krzesło i postawi A2 na podłodze jak w kroku 3. Popchnij nog A1 do A2 lub poci gnij w przeciwnym kierunku, a cztery nogi b d na tym samym poziomie.

2.

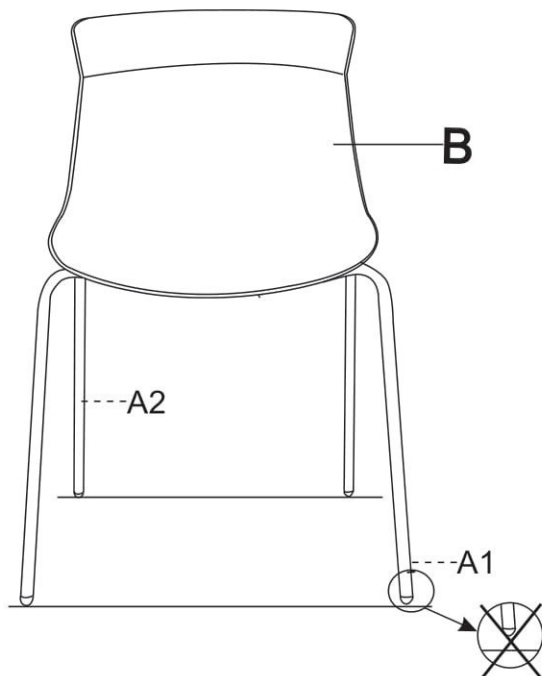

EASY A - 7-08A-4



4.

