



## **BIURKO FADO 3S**

### **BIURKO FADO 3S**

**SPRAWDZENIE JAKOŚCI**

**SPRAWDZENIE WYMIARÓW**

**SPRAWDZENIE NAWIERCENÍ**

**ELEMENTY WG SPECYFIKACJI**

**PROWADNICE 350 mm - 3 KOMP.**

**PŁYTA DO SZUFLAD WG. WYM. - 3szt.**

**AKCESORIA**

**INSTRUKCJA**

**GWARANCJA**

**NR. PAKOWACZA**

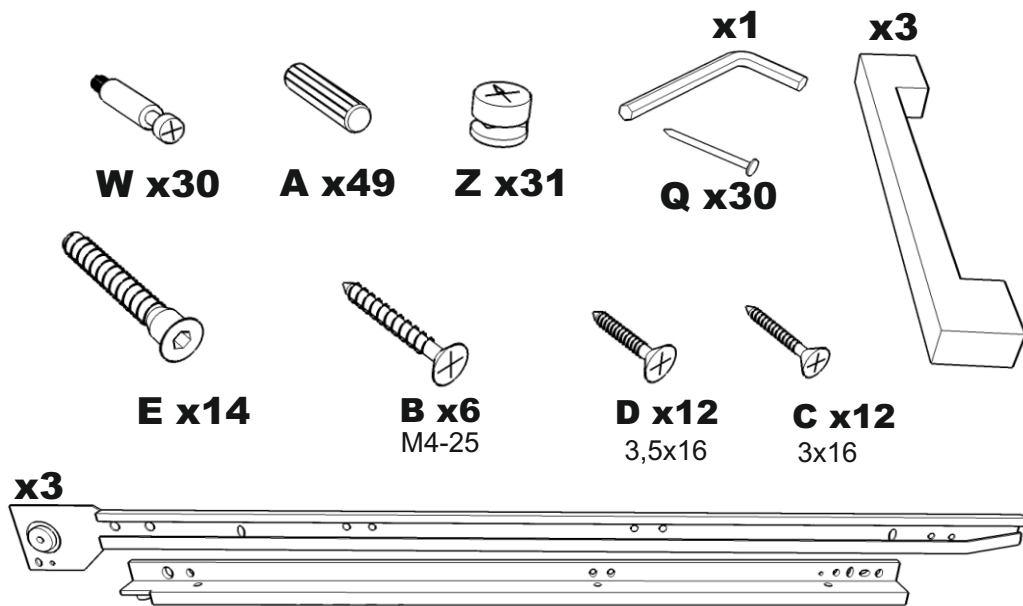
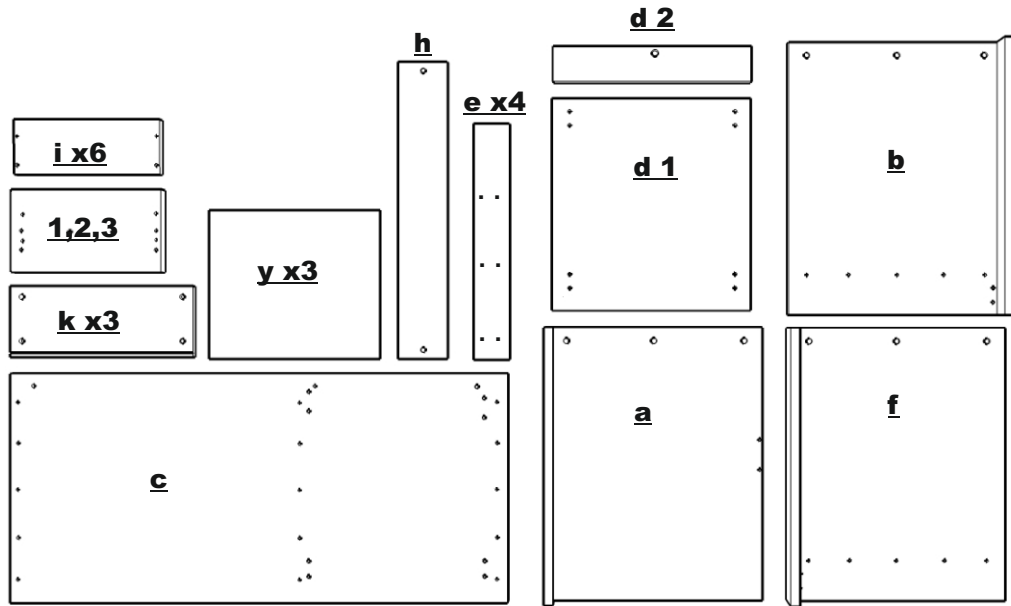

1.

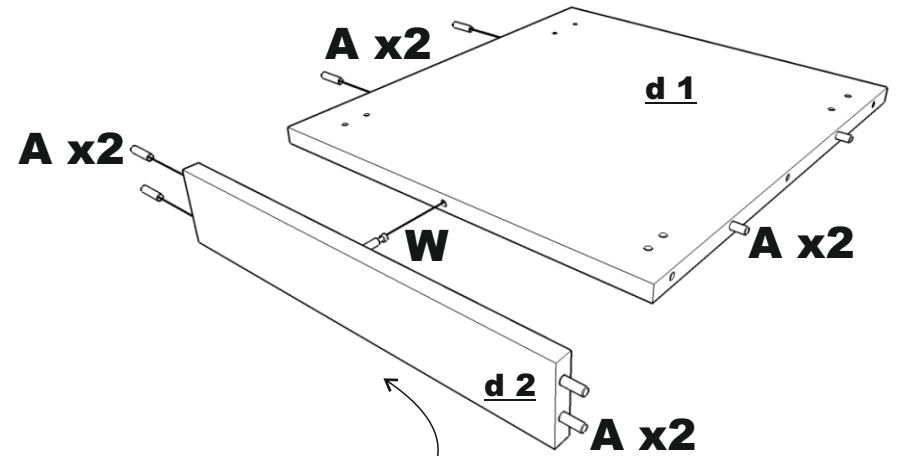

2.



3.

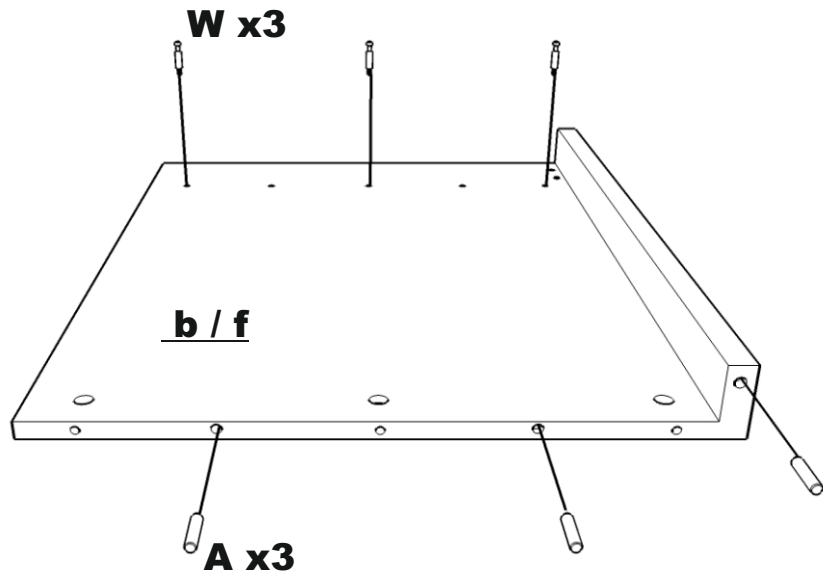

4.

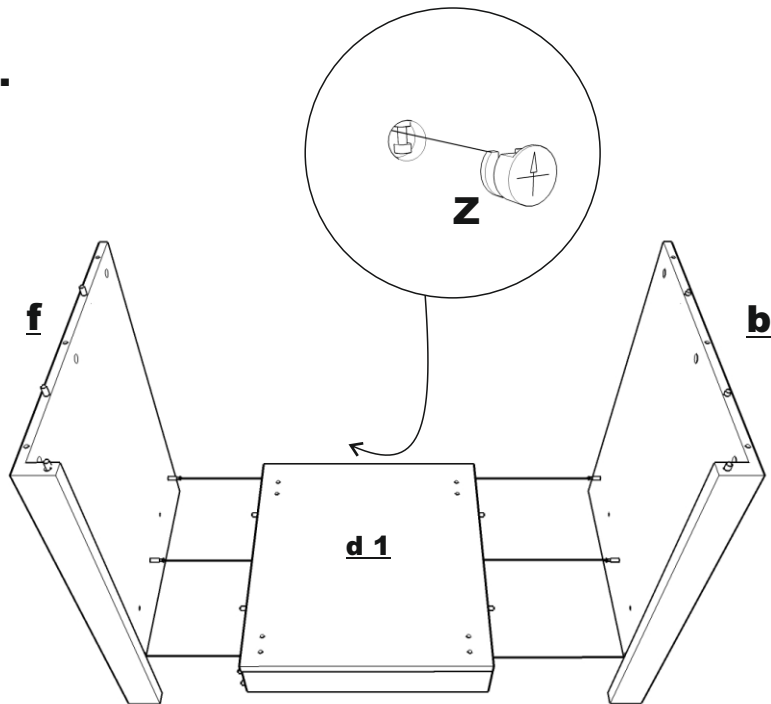

5.

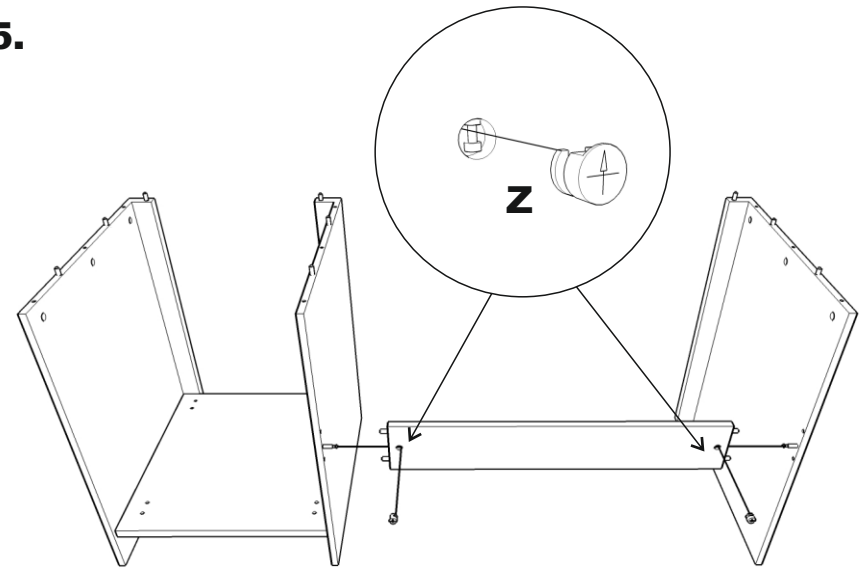

6.

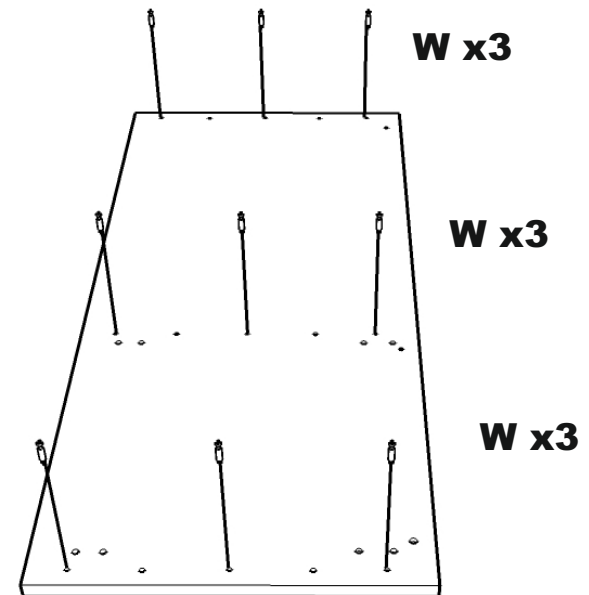

7.

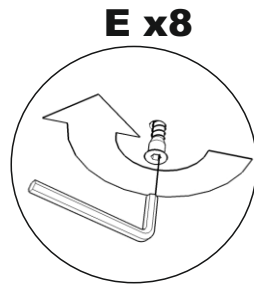
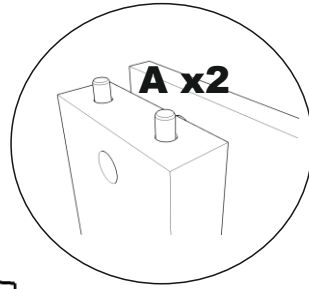
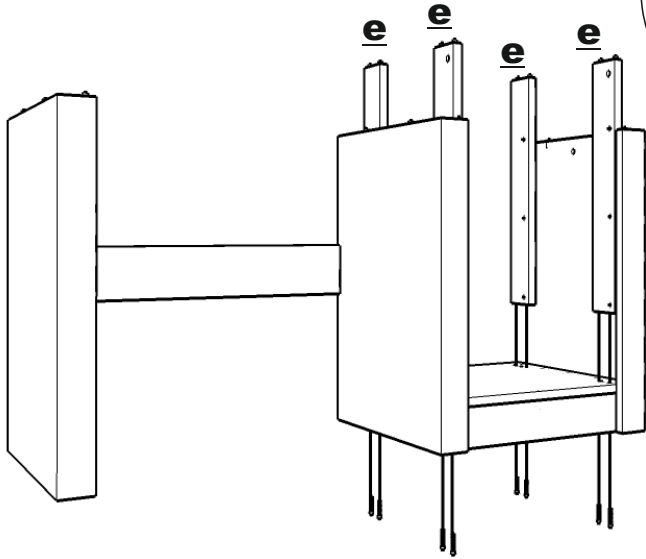

E x2

8.

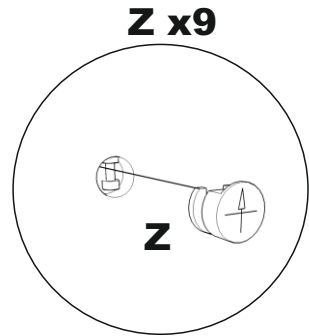
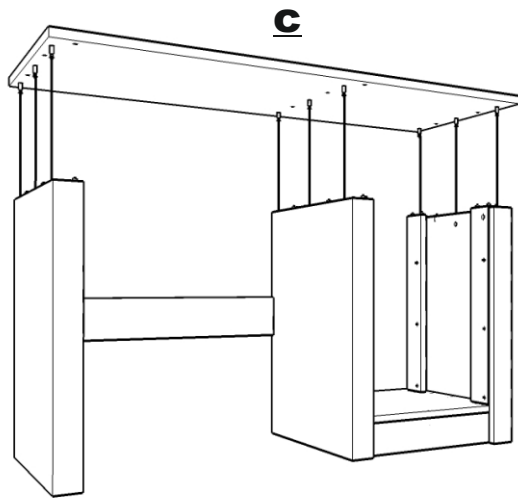

Z x9

Z

9.

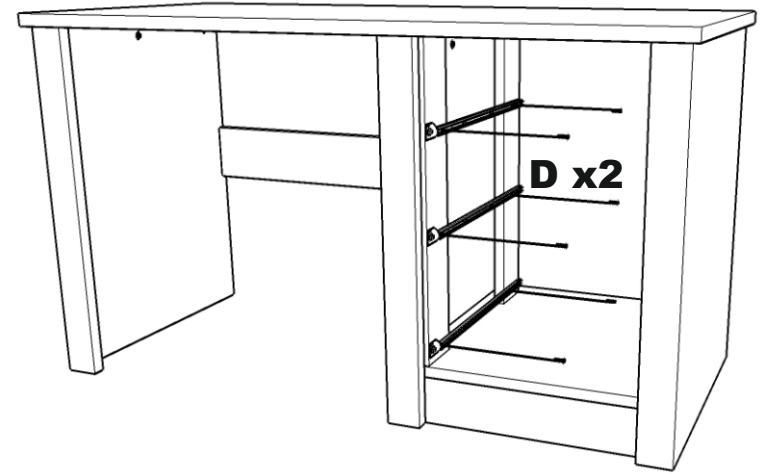

10.

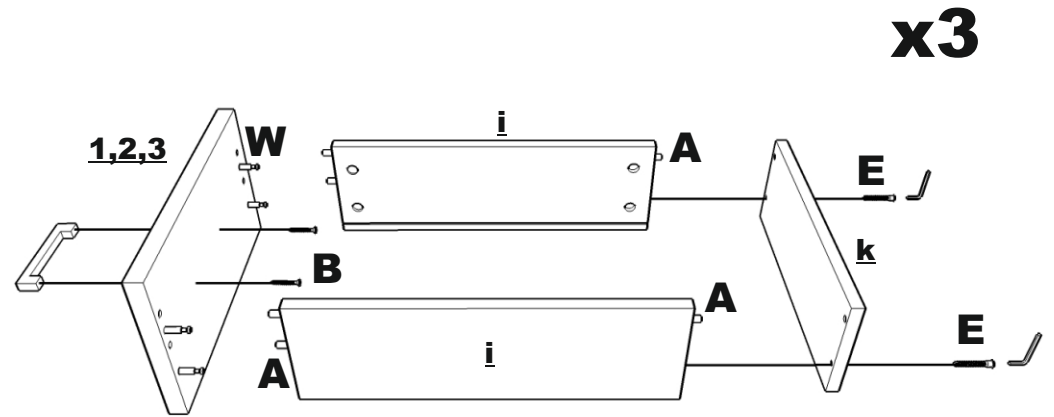

x3

11.

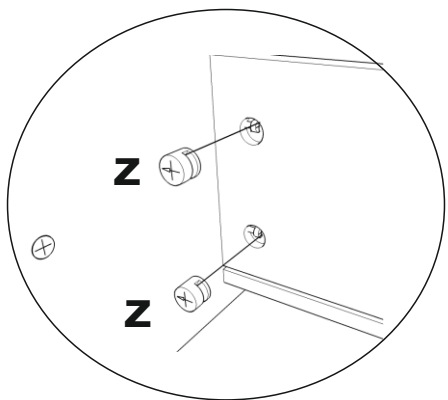

12.

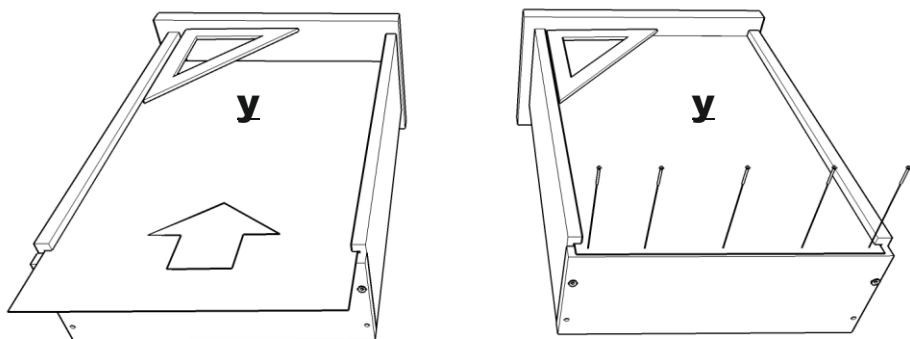

13.

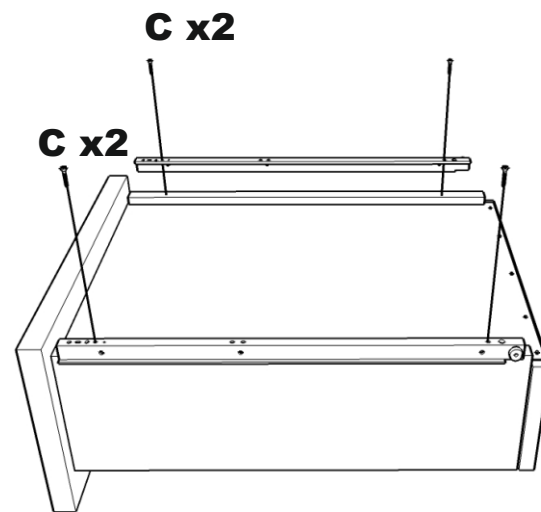

14.

